

**FANTIC**



CUORE ITALIANO

2025 Range World Premiere

2024

Another year  
rich of success



championships

NATIONAL+ INTERNATIONAL

# FANTIC *moto2* RACING

## A DREAM SEASON

2° POSITION IN THE MOTO2 WORLD CHAMPIONSHIP



3 VICTORIES



4 PODIUM



5 POLE

1<sup>ST</sup> EVER MXGP QUALIFYING RACE VICTORY



EMX125 CHAMPIONS



MX SEASON HIGHLIGHTS



1<sup>ST</sup> AND 2<sup>ND</sup> JUNIOR WORLD CHAMPIONSHIP



125 ROOKIES CUP CHAMPIONS

ENDURO-MOTARD  
NEW LINEUP  
50-125-250 MY25

# Motard and Enduro 50-125-250



MY25 ALL **NEW**

SAFE

ABS double channel

DIGITAL

FRONT LIGHT led  
Full communication on CAN

TECH

exhaust MXGP style  
New suspension on rear  
New swing arm in aluminium

# ABS on 125

Unique  
features FOR  
THIS CATEGORY







NEW DESIGN

NEW WHEELS

NEW DESIGN

NEW PERFORMANCE



# NEW LIGHT

**-50%**

WEIGHT (-300gr)

**+100%**

DESIGN MODERN

**200%**

WIDER VISION

# FEATURES

BETTER TORQUE

E5+



EXHAUST **MXGP**  
STYLE

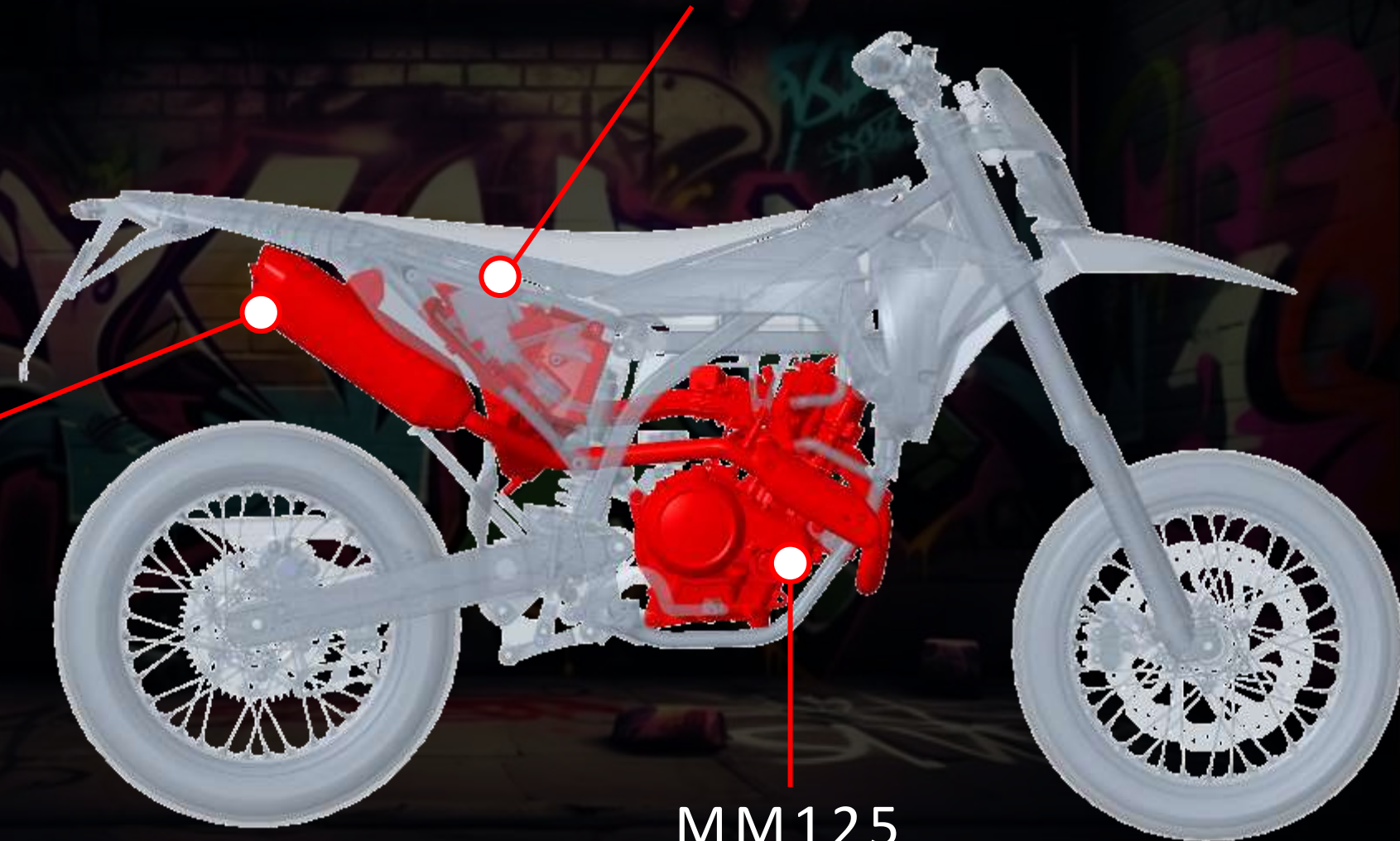

MM125  
**EURO5+**

# CYCLISTIC

## NEW FRONT FORK SETTINGS



### SWING ARM IN ALLUMINIUM AS RACING

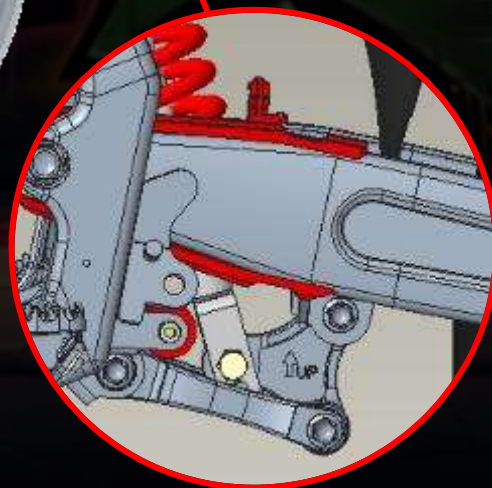

### NUOVO LEVEREDGE PROGRESSIVE

NEW ENGINE FOR  
STREET AND CABALLERO  
500 MY25

A NEW ENGINE, COMPLETELY DESIGNED, DEVELOPED AND ASSEMBLED IN ITALY

**M** PERFORMANT

**M** LIGHT

**M** VERSATILE



COMPACT AND LIGHT  
GOOD FOR SEVERAL APPLICATIONS

SCRAMBLER



DUAL



NAKED



SPORT



...AND MORE...



MAX POWER CLOSE  
TO LICENCE A2 LIMITS

GREAT RPM  
EXTENSION

GREAT TORQUE AT  
LOW AND MID RPM

Power

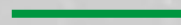

Torque

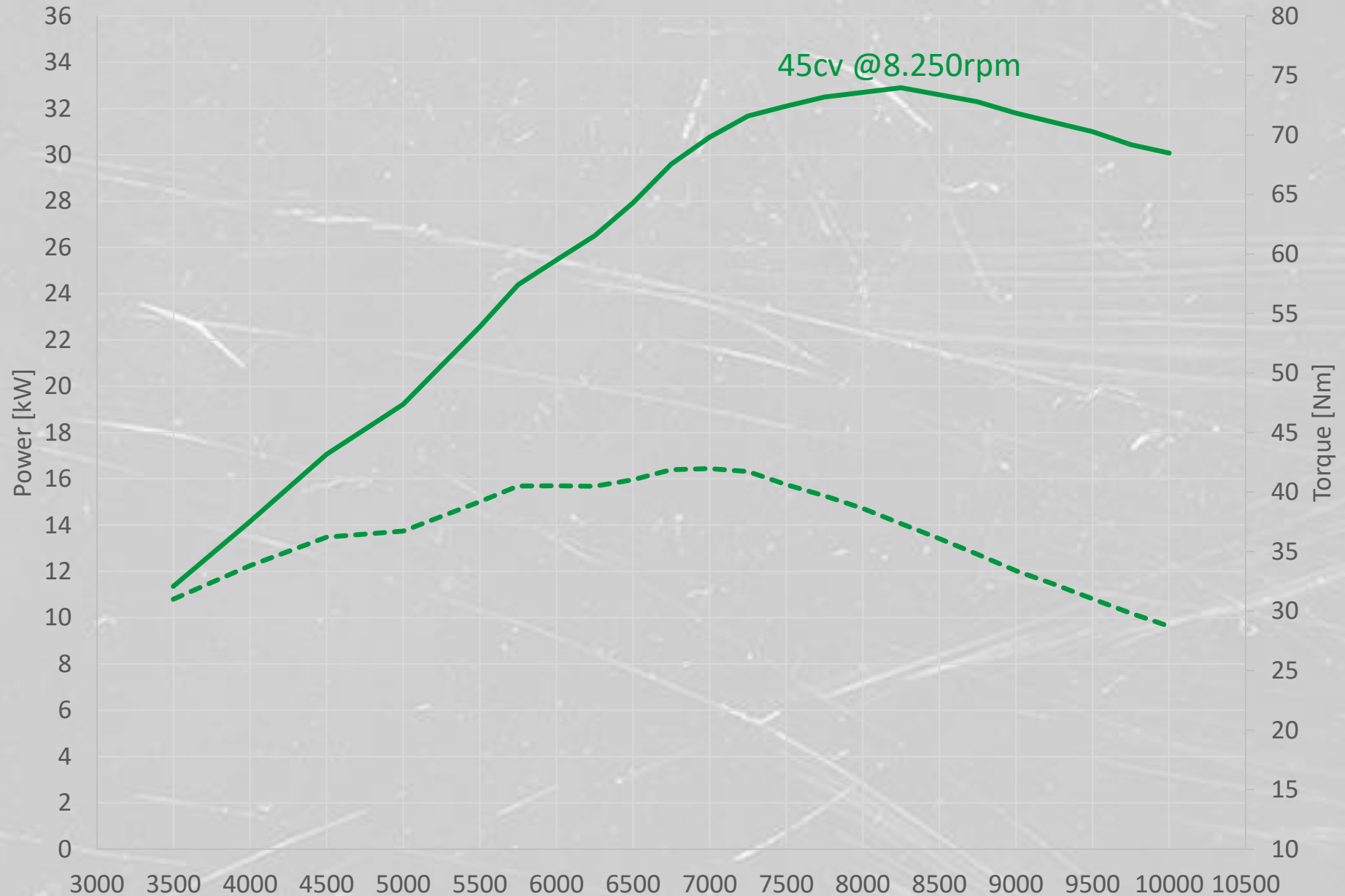



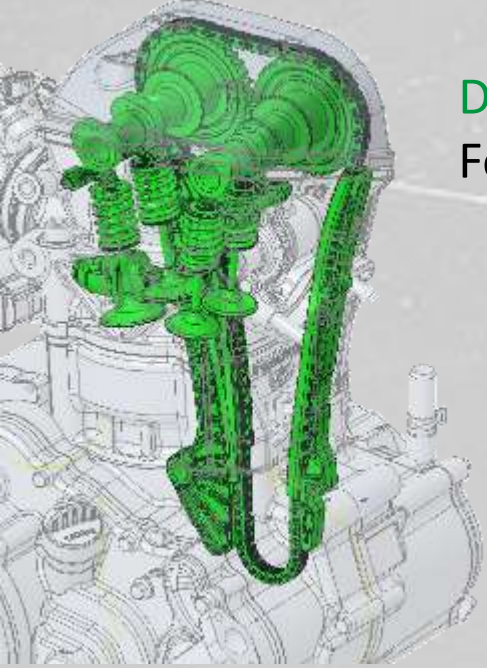

**DOHC WITH FINGER TECHNOLOGY**  
For best torque and power

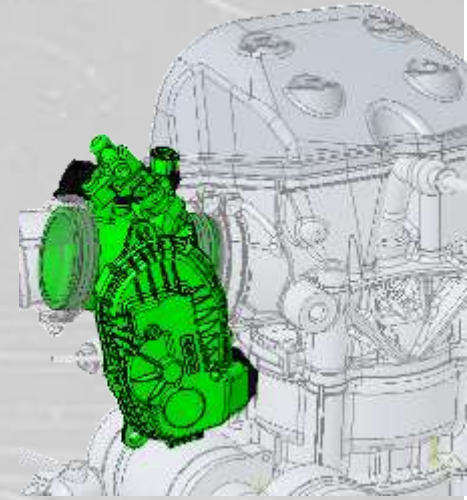

**RIDE BY WIRE**  
For best control at any PRM

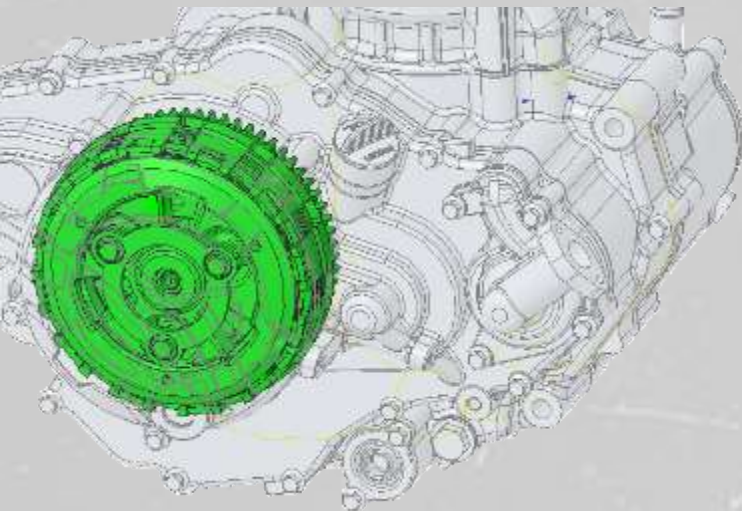

**SLIPPER CLUTCH**  
For a better control on deceleration

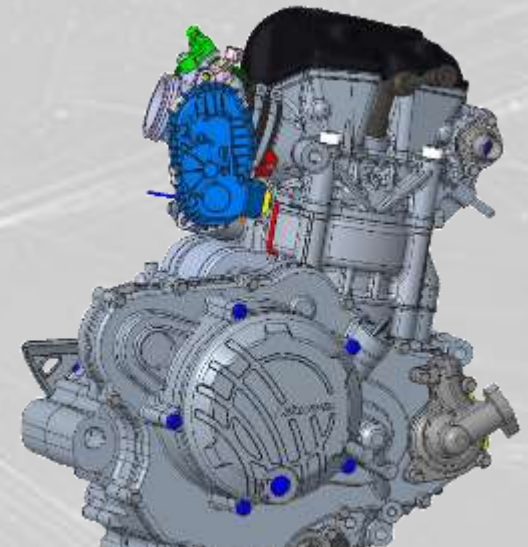

**LIGHTNESS**  
Compact and light (40kg)

NEW STREET LINEUP:  
STEALTH (NAKED)  
IMOLA (SPORT)  
125-500 MY25



**FANTIC**  
RACING TEAM

44  
ARON  
CAN

**FANTIC**

**FANTIC**



**FANTIC**  
RACING

**FANTIC**

ARON  
CANET

TWO MODELS  
TWO CAPACITY

>>>  
500



125  
>>>





500



RIGHT PLACE  
RIGHT TIME

A SEGMENT IN EUROPE  
35.000 PCS/YEAR

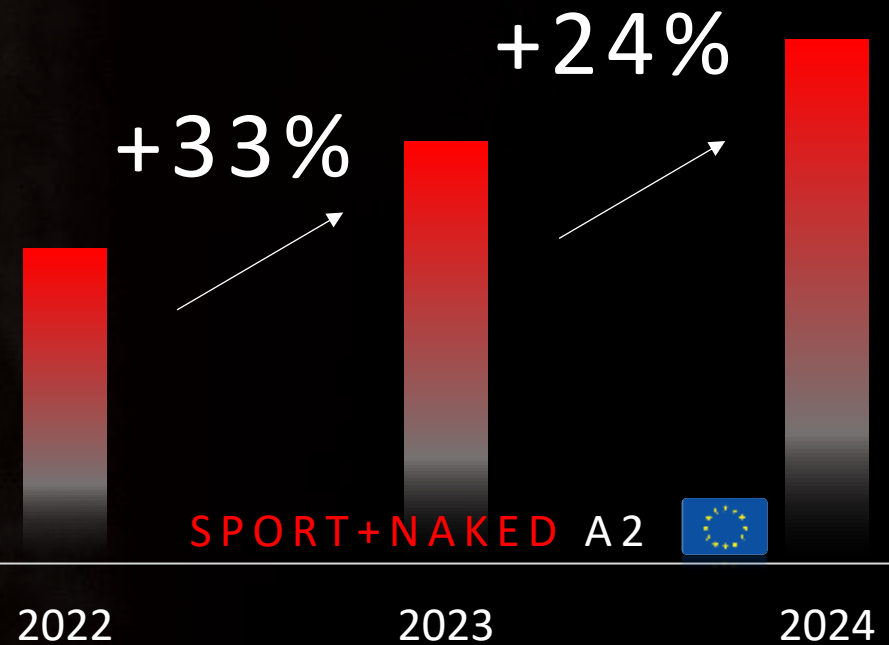

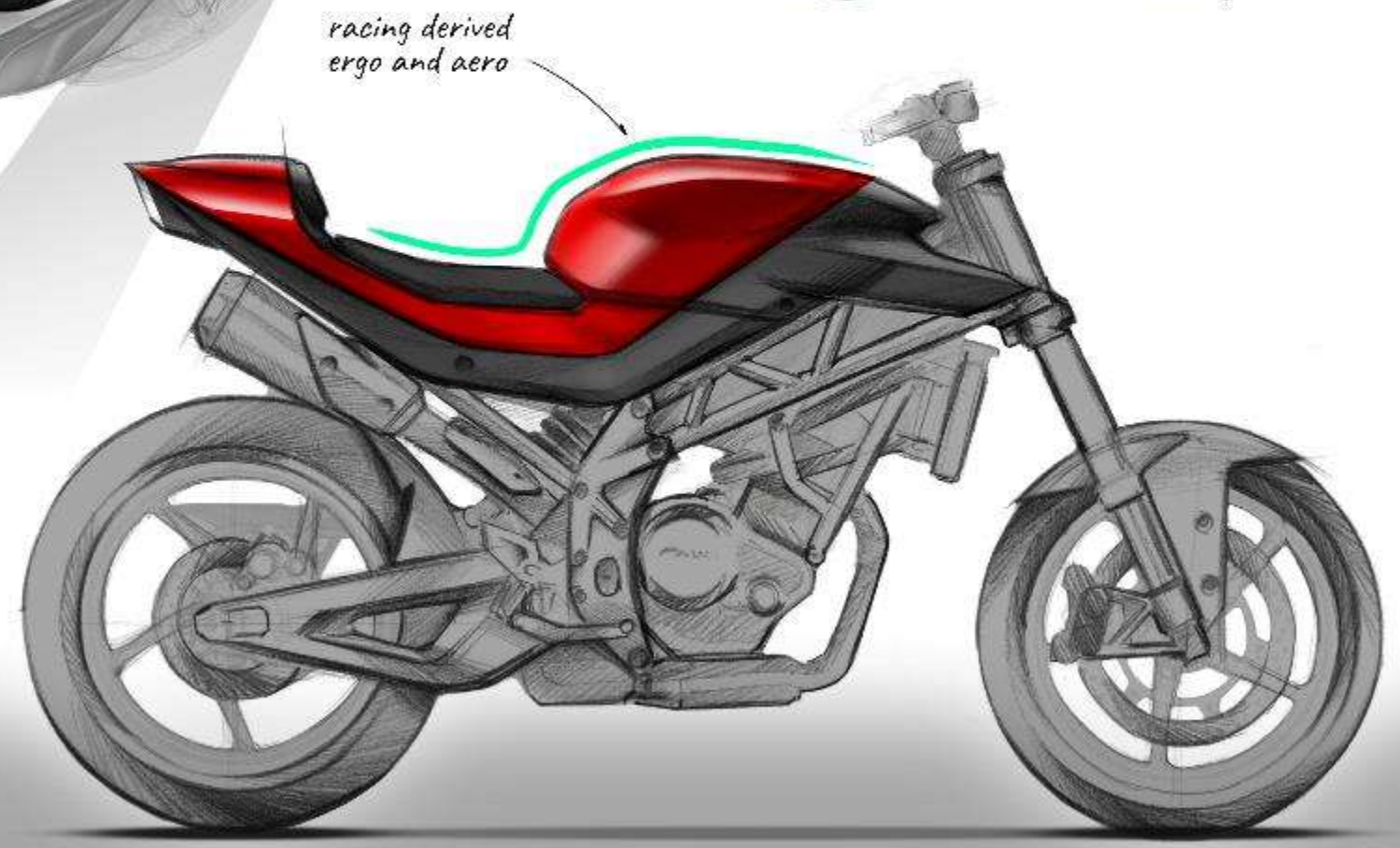
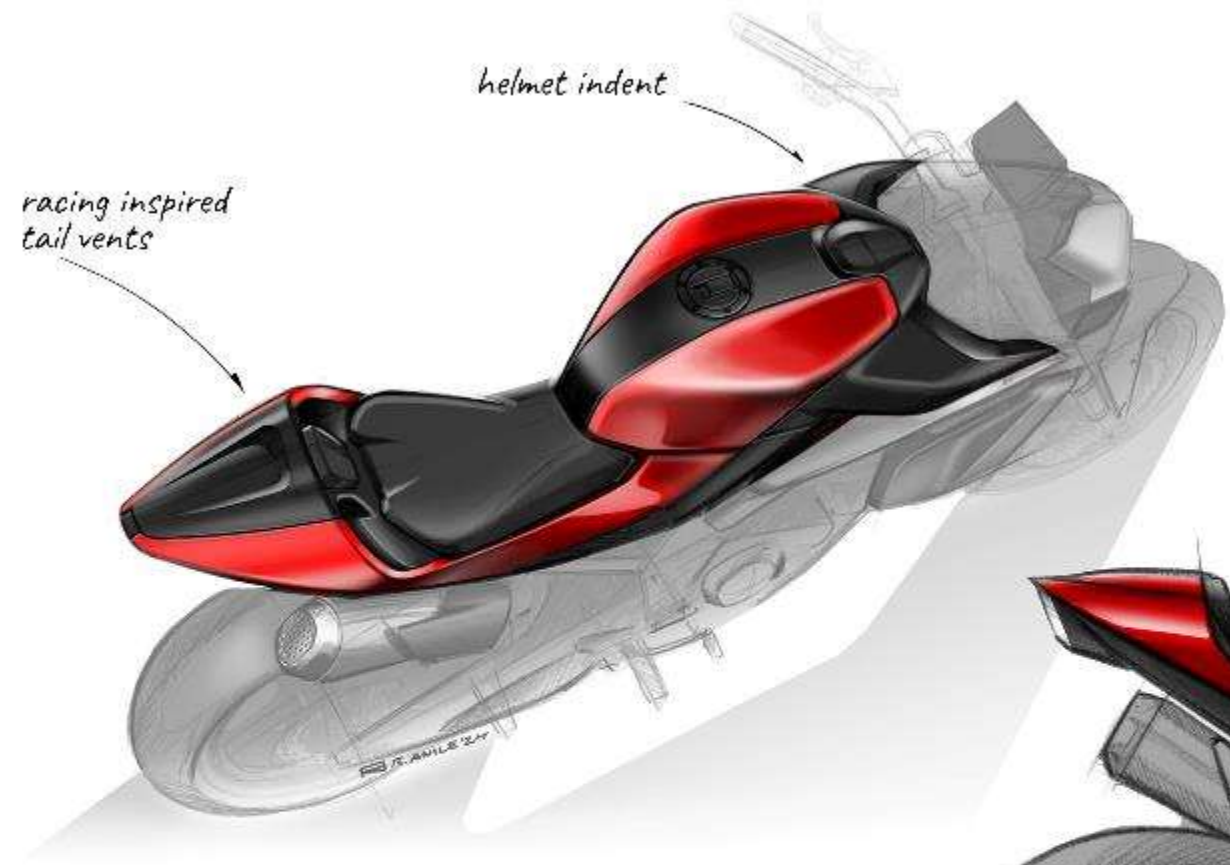

>>>

DESIGN CONCEPT



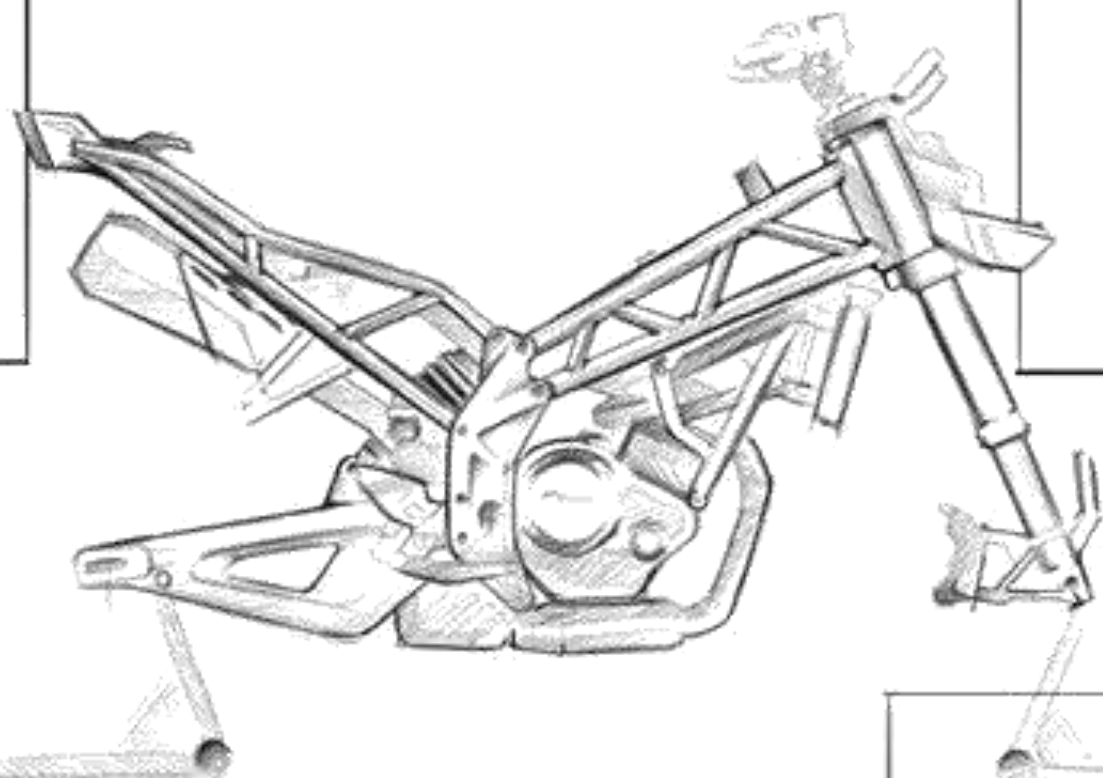
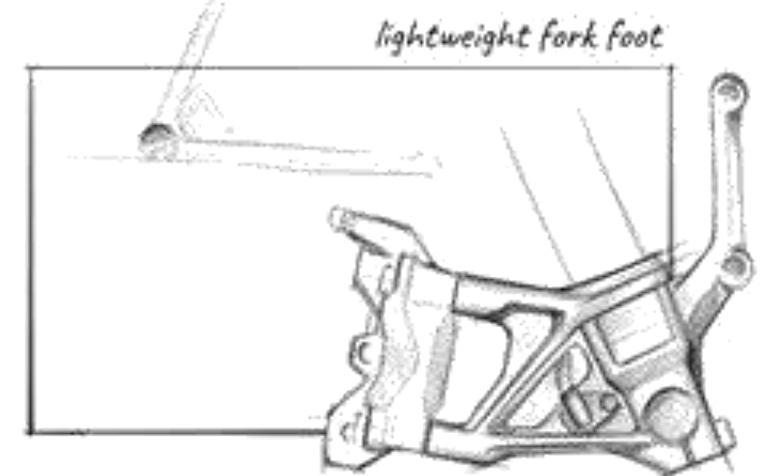
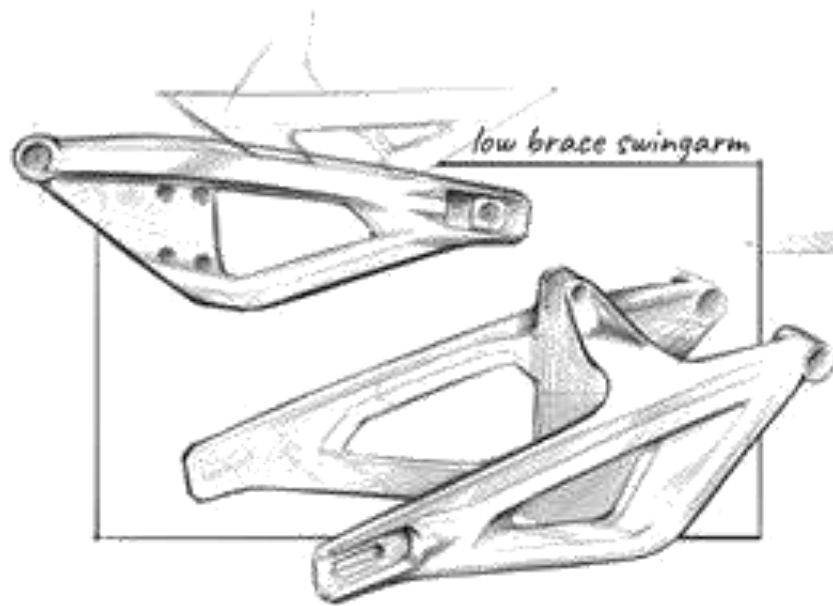
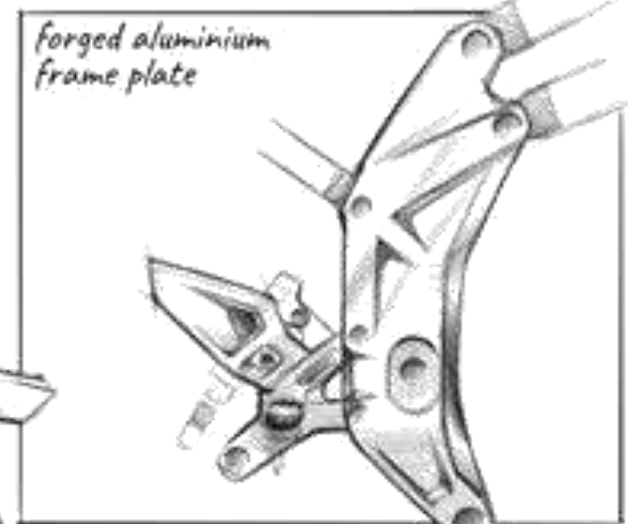
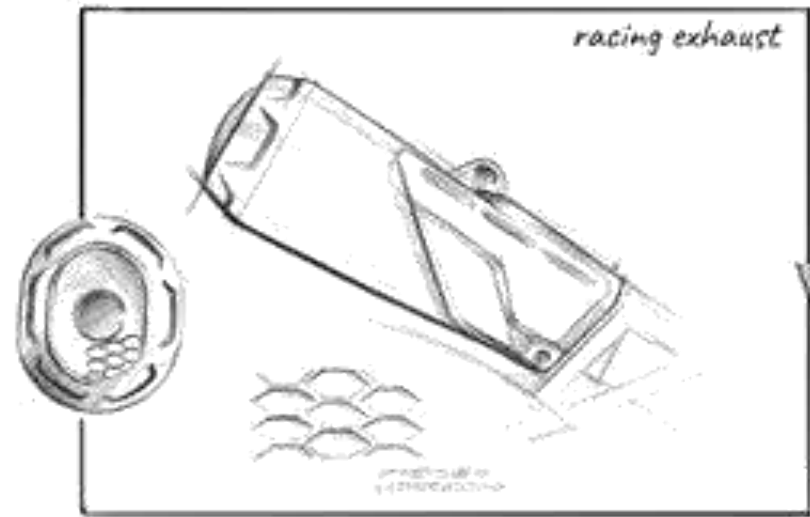



>>> LAYOUT AS RACING

CENTRAL

MASS →

FUN

TO DRIVE

AIRBOX ON FRONT

TANK ON CENTER

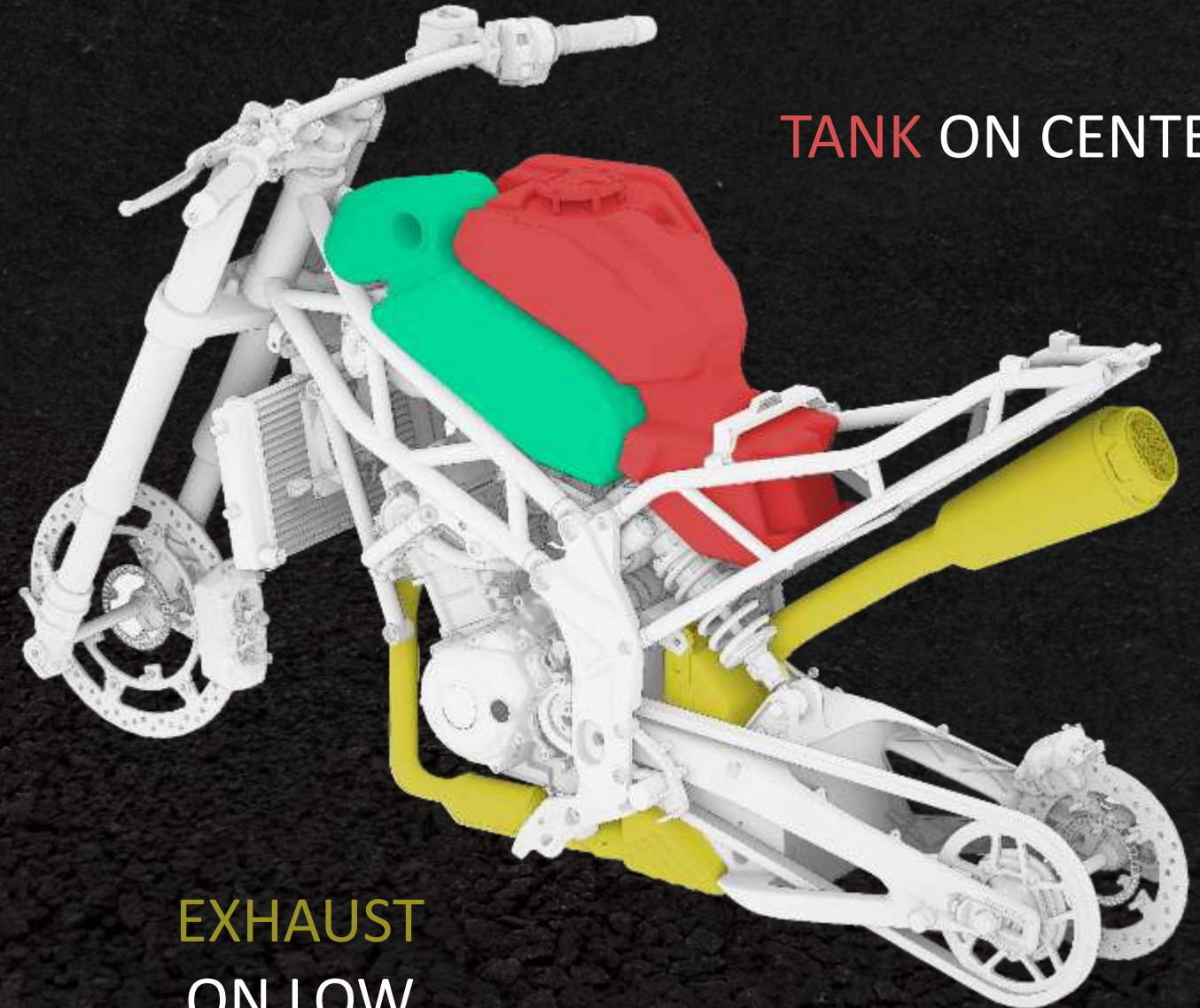

EXHAUST  
ON LOW

# >>> FRAME RACING

ALLUMINIUM  
SWINGARM  
WITH LOWER  
SUPPORT

MIX DESIGN TO  
OPTIMIZE  
PERFORMANCE

FRONT DESIGN  
IN TUBULAR

SIDE DESIGN IN  
FORGED ALUMINIUM

>>> 500: REAL SUPERMONO

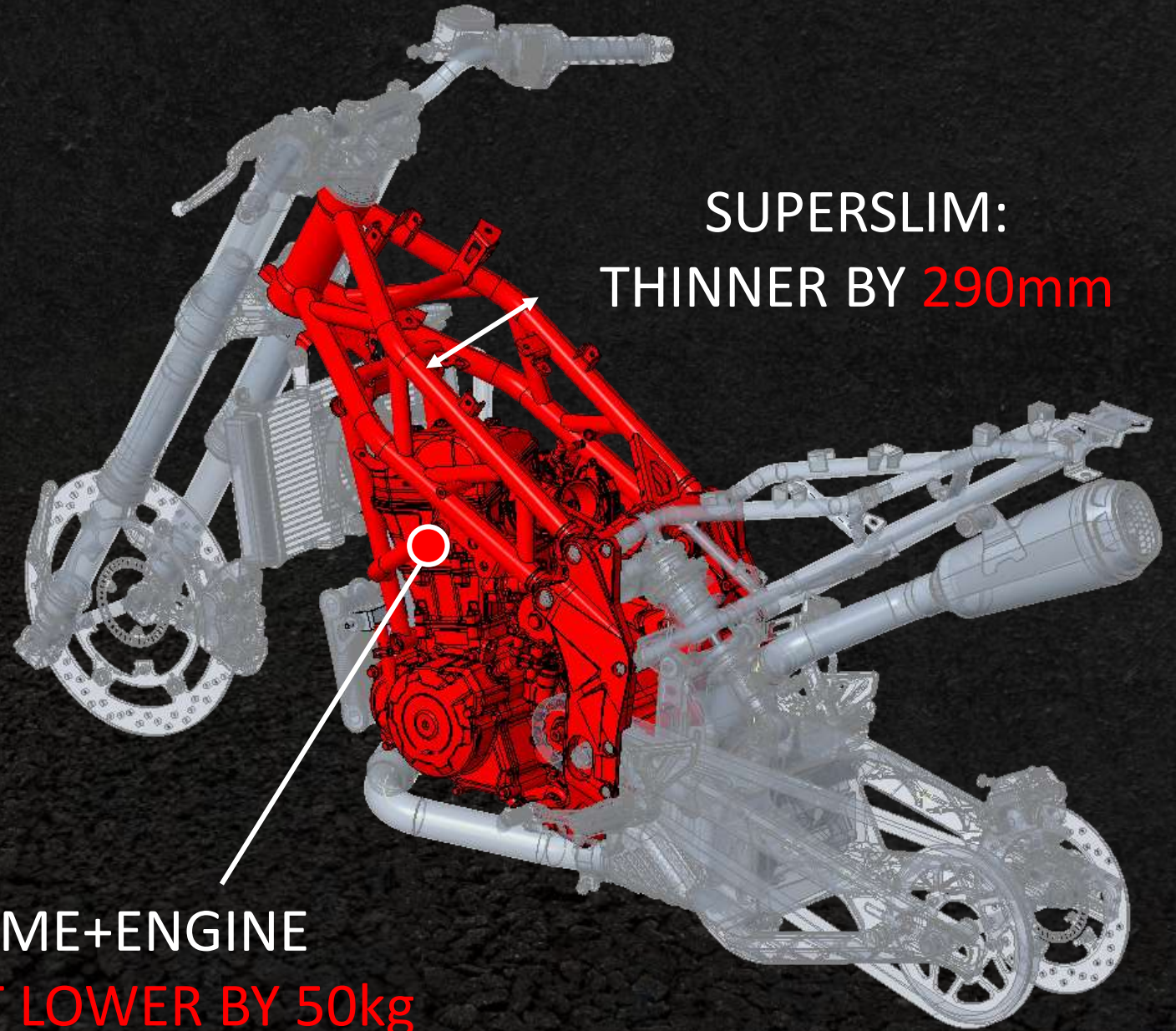

SUPERSLIM:  
THINNER BY 290mm

FRAME+ENGINE  
WEIGHT LOWER BY 50kg

>>> ELETTRONIC

>>> TFT 5"

>>> TC + ABS CORNERING

>>> LIGHT FULL LED



# NEW CABALLERO 125-500 MY25



# CABALLERO

## MY25



# SCRAMBLER & DELUXE



19" FRONT

A NEW BIKE  
BUT TWO



21" FRONT

RALLY,  
DUAL SPORT



FEATURES



DAILY RIDE

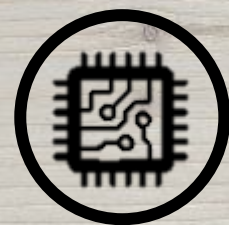

TECH PACK

**CABALLERO**

MY25

A REAL UPGRADE





# PRESTAZIONI

45CV (+15%) EXTRALIGHT (150KG)

=

**GREAT FUN**

## NEW AIRBOX

Designed with CFD3D tech to improve airflux and turbolences

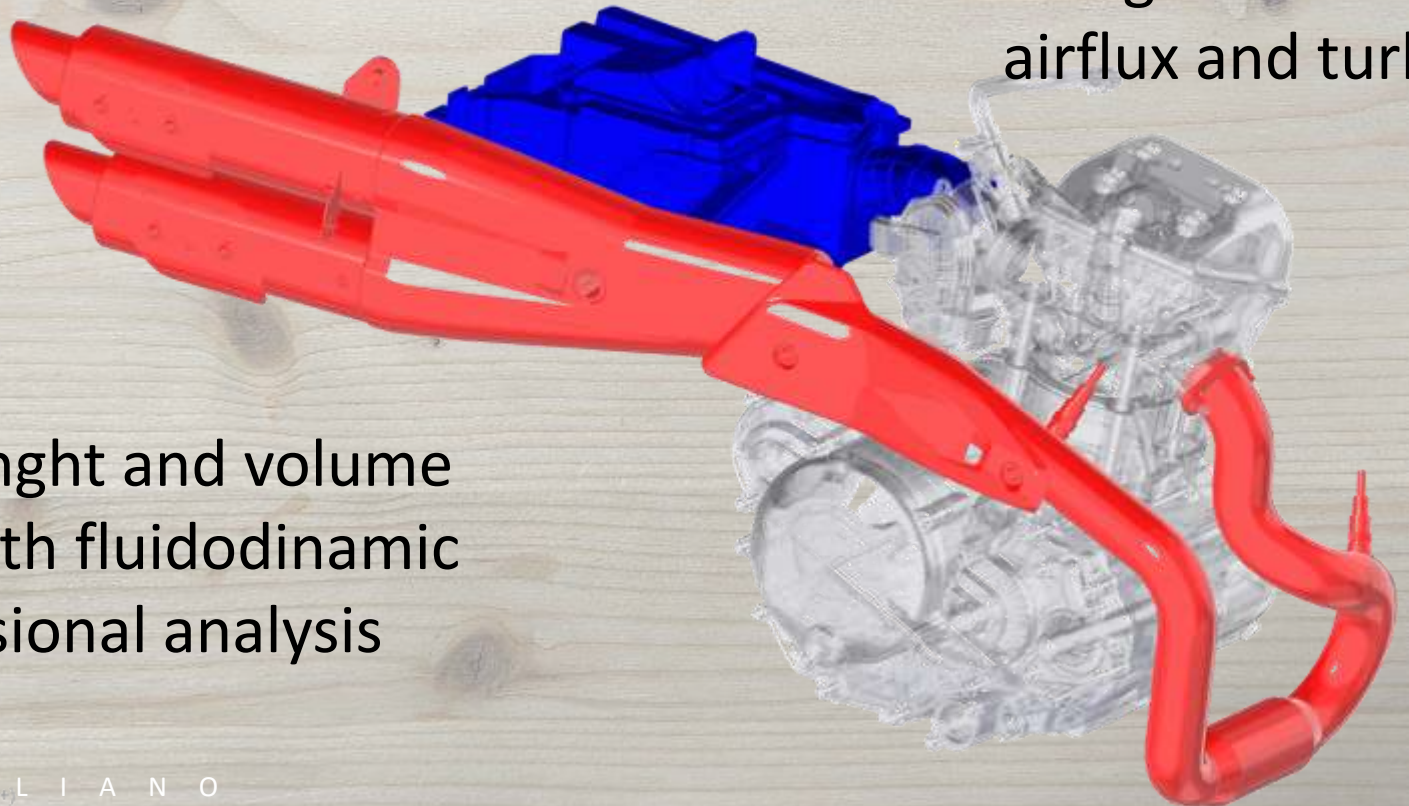

## EXHAUST

Diameter, lenght and volume optimized with fluidodinamic monodimensional analysis



# NEW COOLING SYSTEM

**CABALLERO**

MY25

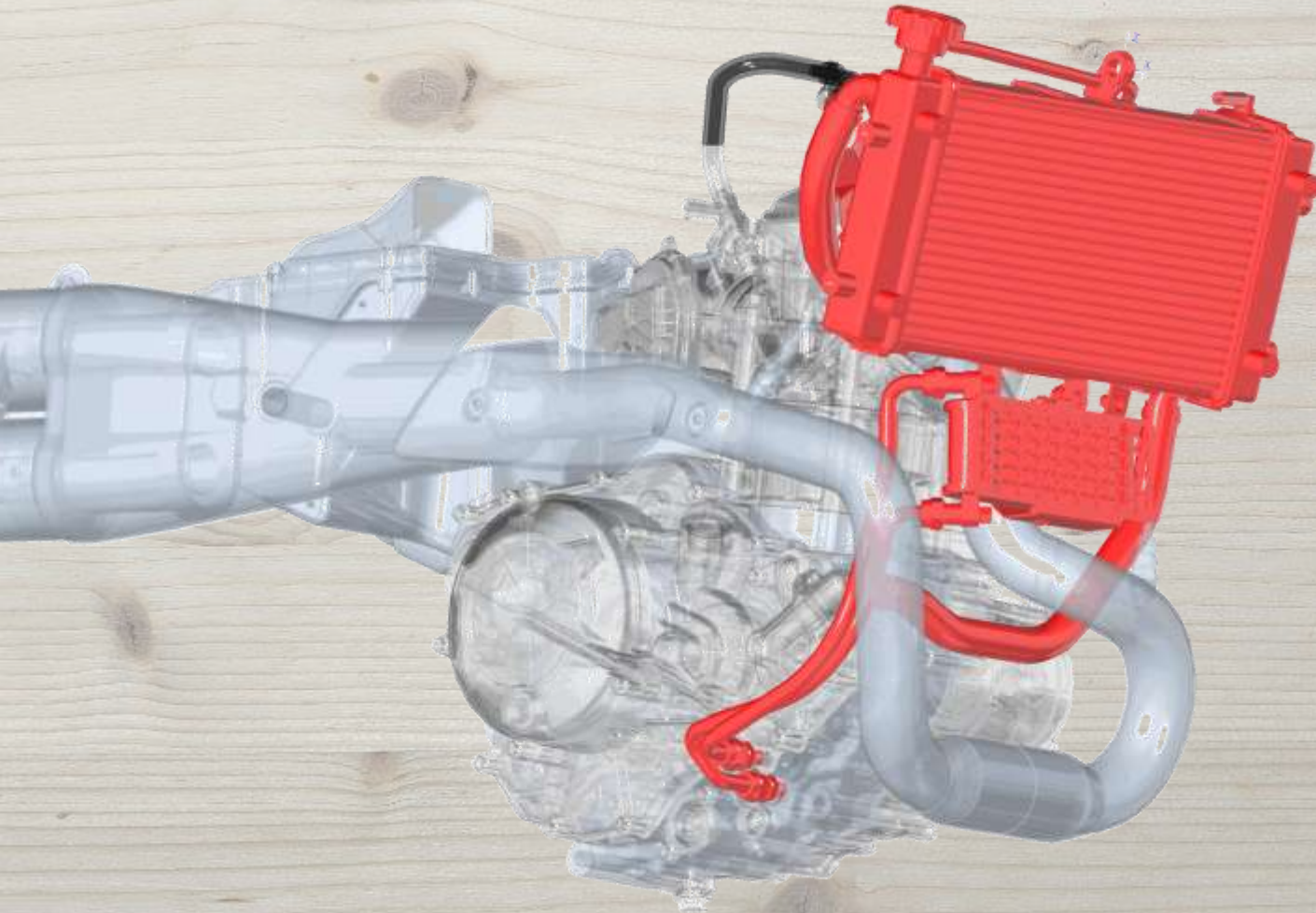

**WATER RADIATOR**

Surface +15%

**OIL RADIATOR**

Engine oil temp.: -10%

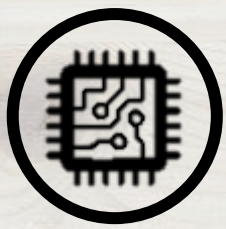

TECH PACK



STREET

TC ON

ABS ON



ALL TERRAIN

TC OFF

ABS REAR OFF  
/FULL OFF

The only in this category with ABS CORNERING and TC, **ESCLUSIVELY**

**CABALLERO**

MY25





DAILY RIDE

CABALLERO

MY25

Improved CONFORT  
& **ERGONOMY**



30mm THINNER

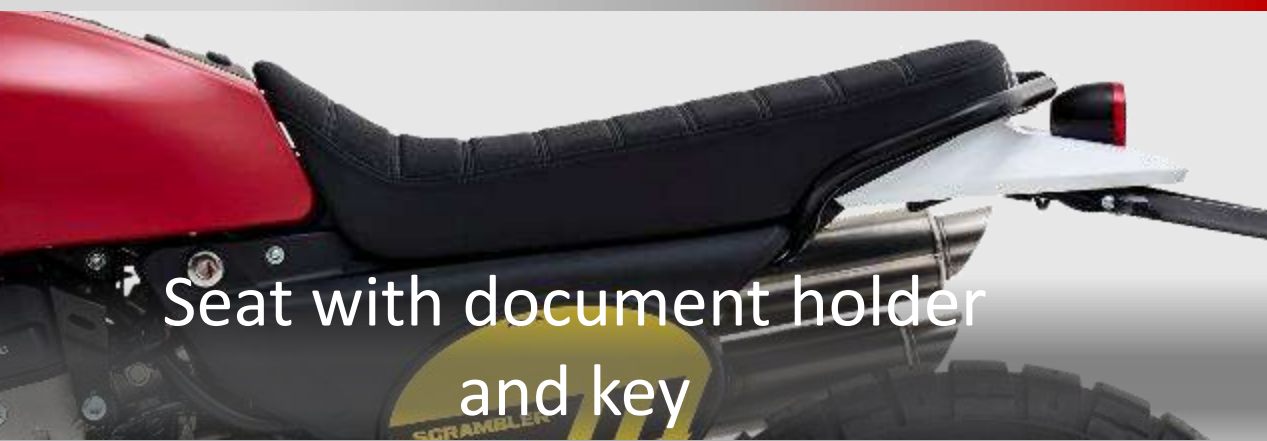

Seat with document holder  
and key



Redesign passanger handles

**CABALLERO**

RALLY MY25



The real DUAL

# THE 10 RULES FOR A PERFECT DUAL SPORT



1. FRONT WHEEL 21"
2. PERFECT ERGONOMICS FOR STENDUP DRIVE
3. ADJ SUSPENSION WITH 200mm STROKE
4. SUPERLIGHT: 149Kg
5. CLEARANCE 280mm
6. STEARING 24,5° (+0,5°)
7. SKIDPLATE PROTECTION
8. PROTECION FOR LIGHT
9. PIRELLI SCORPION RALLY STR
10. WASHABLE FILTER

LAST BUT NOT **LEAST**

**CABALLERO**  
**700**



# DELUXE 700



NEW GREY  
CAMPOVOLO

3 STRIPE  
GRAPHIC

HANDLEBAR  
COVER



# TRAVEL 700



NEW COLOR  
TUNDRA GREEN

TRAVEL KIT

WINDSHIELD  
SPORT





THANKS

**FANTIC**



CUORE ITALIANO

2025 Range World Premiere